

Operation Instruction
W Series
Permanent Magnet Synchronous
Gearless Traction Machine



Please provide the Instruction to end users (for installation, operation, maintenance and care, etc) and properly keep it.

Foreword

Thank you for choosing our product, and we will whole-heartedly provide you with high-quality services.

The permanent magnet synchronous gearless traction machine (hereinafter referred to as traction machine) adopts advanced design concept and manufacturing process and features compact structure, small volume, light weight, low energy consumption, low noise, high efficiency, etc.

The design and production of traction machine conforms to all relevant provisions of GB7588-2003-Safety Rules for the Construction and Installation of Electric Lifts, EN81-1:1998- Safety Rules for the Construction and Installation of Electric Lifts and GB/T24478-2009-Traction Machine of Electric Lifts.

This Operation Instruction describes the method of correctly using the traction machine, and the diagrams in the Operation Instruction are representative examples, and the actual product may be different.

General Precautions

1. The Instruction may be appropriately changed owing to product improvement, specification change and convenient use of the Instruction and the Company reserves the right to modify the Instruction, and its contents are subject to change without prior notice.
2. After opening the packing box, please confirm whether the product is consistent with the model and specification of order. Misuse of different product may lead to damage of electric elevator or traction machine and casualties.
3. Please carefully check the rated load capacity of lifting appliance according to the weight indicated on product nameplate and the hoisting method specified in the manual, and if the load capacity of lifting appliance is insufficient, there is the danger of product falling-off, turnover and casualties.
4. If the data are damaged and lost or the product nameplate becomes illegible and is damaged, please order the Instruction from the Company according to the contact information on the back cover.



Warning: Safety Instruction

- ① Carefully read the Instruction and relevant subsidiary information prior to installation, operation, maintenance and care, so as to avoid equipment damage and casualties.
- ② During installation, operation, maintenance and care, please operate the product in strict accordance the Instruction, so as to guarantee the equipment in normal condition and personal safety.
- ③ In some description of the illustration of the Instruction, the enclosure or safety cover is in removed status so as to describe the details, however, be sure to restore the enclosure or cover as specified before running of the product, and the operation and running of the product should be in accordance with the Operation Instruction.
- ④ Forbid non-professionals to operate the product.

Common Safety Precautions

The paragraphs and sentences with the safety sign  are important contents, so be sure to comply with them, and misuse of them may lead to personal injury and equipment damage, and even casualties when the situation is severe!

Handling, installation, wiring, running, operation, inspection, maintenance and care of the product should be conducted by professionals.

The Company will not bear liability if the customer uses the product not in accordance with the design requirements or purposes.

If the customer modifies the product, the product will not be within the warranty, and the Company will not bear liability.

- The packing box is applicable to handling with shovel car or forklift, and appropriate loading and unloading equipment must be selected according to the weight and dimension at the handling.
- Please prevent falling-off, turnover, and impact when handling the packing box, and when it's needed to stack up the packing boxes, the height should not be higher than the stacking-up height indicated on packing box.
- After receiving products, check their appearance, and if there is damage, please timely contact the Company.
- After receiving products, please confirm whether they are consistent with the ordered products, and if they are different, please timely contact the Company.
- After removing the packing box, take necessary dustproof, rainproof and moist-proof protective measures.
- Before hoisting the traction machine, please confirm the weight of traction machine, and at the hoisting, use the lifting ring or lifting hole on the traction machine, and guarantee vertical hoisting.
- When handling the traction machine, prevent falling-off, turnover, and impact of the machine, and if it has been installed on the frame, don't hoist them entirely.
- Please don't use the product in the explosive air with smog and dust, and there should be no obstacle and inflammables around the traction machine.
- Forbid installing and using the product in the places where water drop and greasy dirt are dripping, particularly, don't allow the water drop and greasy dirt to adhere to the brake wheel or traction sheave rope groove.
- Please don't remove the nameplate, label and warning sign on traction machine, and please install the traction machine and its accessories according to provisions and requirements.
- Please don't touch sharp parts of traction machine with bare hand, and don't put your finger or the article into open position of traction machine.
- Prior to debugging and use, measure the insulation resistance of traction machine stator and brake, and it should not be lower than $0.5M\Omega$, and forbid touching the terminal at the measurement.
- In electrical operation, please guarantee good insulation of traction machine and complete equipment and additional or auxiliary circuit.
- Please conduct wiring according to electrical specifications, and don't directly conduct wiring from commercial power supply, and don't conduct wiring to the control cabinet except the special control cabinet.
- Please be sure to conduct reliable grounding if there is grounding identification or requirement.
- Before mechanical connection, be sure to confirm the rotational direction of traction machine.
- Please don't sit or rely on traction machine, and it's absolutely not allowed to approach or contact the rotating part in operation.
- As the surface temperature of traction machine and brake is very high during running, please don't touch them with hand or body.
- In case of adjustment, replacement or failure of the brake, please be sure to adopt effective precautionary measures to prevent the lift car and counter-weight from falling off.
- Before repair and maintenance, be sure to first stop running of the whole elevator system and ensure that the traction machine is not in use.
- When injecting or discharging the bearing lubricating grease, follow the requirements and pay attention to the rotating parts.
- Before the product is used after it has been stored for a long time, check it according to the above provisions, and operate the motor at low speed ($<20\text{rpm}$) in both forward and reverse direction to lubricate the bearing evenly.

Contents

1. Product Introduction	1
Structural Principle	1
Specification Parameters	1
Working Conditions	1
2. Installation and Connection	2
Installation of Traction Machine	2
Connection of Main Terminal	2
Connection of Brake	2
Connection of Encoder	3
Connection of Safety Switch	3
Installation of Brake Releaser	3
3. Debugging and Running	4
Debugging	4
Running	4
4 Maintenance	5
Maintenance Checklist	5
Supply of Lubricating Grease to Bearing	5
5. Fault Diagnosis	6
6. Emergency Rescue	8
7. Appendix	9
Adjustment of Brake	9
Brake Wire Releaser for Machine Roomless	11
Replacement and Installation of Encoder	13
Connection illustration of Encoder	14

1. Product Introduction

Structural Principle

- The traction machine is comprised of permanent magnet synchronous motor, traction sheave and braking system.
- The traction machine adopts high-performance permanent magnet materials and special motor structure, and has low rotational speed and high torque.
- YW series is outer rotor structure, the braking system is block brake structure, and the traction sheave and brake wheel adopt coaxial fixed connection, and are directly installed on drive end of motor.
- A limit switch is installed on the brake to monitor braking, and when the brake opens, the normally open contact of limit switch will be closed.
- Working principle of traction machine: The traction sheave on drive end of motor outputs torque and through the friction between traction sheave and steel wire rope, drives the elevator car to run. When the elevator stops running, the normally closed brake plays a braking role through the brake shoe, so as to keep the elevator cabin still when the traction machine is de-energized.
- YW series can be used for machine room or machine roomless.
- Each traction machine has passed strict quality inspection before leaving the factory, so as to guarantee the product quality and performance.

Specification Parameters

Model	YW400
Voltage	380V
Roping	2:1
Wrap	Single
Elv. Load	630-1600kg
Elv. Speed	0.5-2.5m/s
Sheave Diam.	400mm/450mm
Duty	S5-40%ED
Starts Per Hour	240st/h
Max. Static Load	4000kg
Weight	350kg
Brake*	DC110V 2×1.3A
IP Code	IP41
Ins. Class	F

*The voltage and current value of brake is the total value.

Optional AC 220V rectifier for brake.

Working Conditions

- The height above sea level should not be greater than 1,000m.
- The product is used indoors, and the ambient air should not include corrosive and inflammable gas.
- The ambient temperature should be kept within 0-40°C.
- The mean monthly relative humidity should not exceed 90% at most and the mean monthly minimum temperature of such month should not be higher than 25°C.
- The diameter of traction steel wire rope should not be more than one fortieth of the diameter of traction sheave, and there should be no lubricant and other sundries on its surface.
- The traction machine must be supplied with power by control cabinet and adopt closed-loop control, and its rated parameters should be subject to the nameplate of traction machine.
- The deviation between supply voltage variation and rated value of control cabinet power supply should not exceed $\pm 7\%$.

2. Installation and Connection

2.1 Installation of Traction Machine

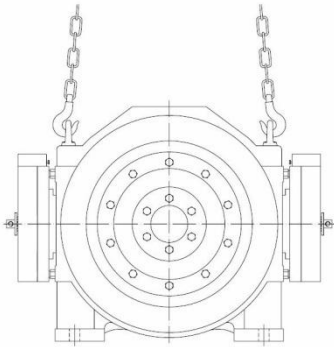

Hoisting Diagram

⚠ Caution

- Before installation of traction machine, guarantee the strength of installation frame and foundation.
- Please use the lifting ring or lifting hole on traction machine when hoisting the traction machine.
- Be sure to adopt vertical hoisting in hoisting, and the included angle between two hooks must be less than 90°.
- The installation plane of traction machine should be horizontal and corresponding vibration reducing measures should be taken.
- The hanging steel wire rope and corresponding load should be vertical to the central plane which goes through the traction wheel.
- Ensure that the frame surface for installing traction machine is flat and the maximum allowed deviation is 0.1mm.
- The barring hand wheel of machine room is in the lower left corner of the main engine back, so please pay attention to the involvement of machine frame.
- The size of bolt for fixing traction machine includes the foot hole, and the bolt adopts the bolts with grade-8.8 strength.
- Usually, the traction machine is furnished with anti-trip bar and protective cover, and it should be reset after the steel wire rope is installed.

2.2 Connection of Main Terminal

In main terminal box there are three-phase power line (U, V, W), grounding terminal and thermistor wiring. The connection of power line is on terminal block, the ground wire is on grounding terminal, and the wiring of thermistor adopts the wire connector.

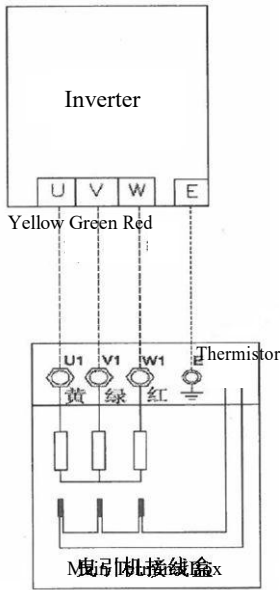

Main Terminal Connection Diagram

⚠ Caution

- Don't connect wiring directly from commercial power supply.
- Connect the inverter as shown in left figure.
- The power cable should adopt shielded cable.
- Reasonably select the connecting cable according to the current.
- The cable screen layer is reliably grounded on single end.
- Separate the power cable from control cable.
- After connection, check whether the open circuit and the short circuit exist.

⚠ Caution

- Please connect the thermistor to thermal protection circuit so as to prevent traction machine from burning due to overheating in an exception.
- PTC thermistor temperature curve is shown in right figure, and the resistance at 130 °C is more than 3,700Ω.

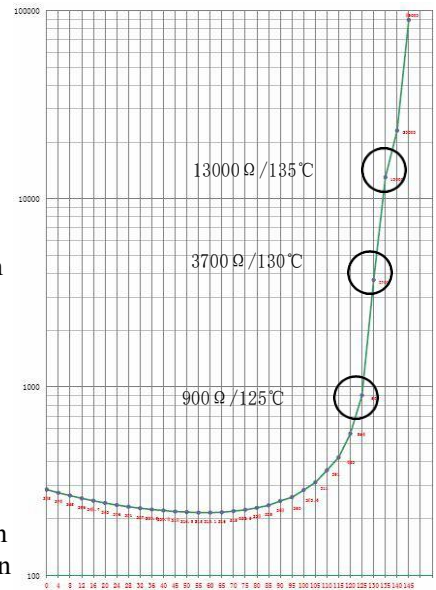

Thermistor Temperature Characteristics

2.3 Connection of Brake

The rated voltage of brake coil is DC110V. One limit switch is provided for the brake on both sides respectively, and the limit switch has two contacts normally open/normally closed for wiring. In standard configuration, the contacts are normally closed, namely, when the limit switch contact is closed, it means that the brake on such side is closed.

⚠ Caution

- To prevent the running of band brake of traction machine or exception of brake, please connect the limit switch of brake to detection circuit, and both sides should be connected in parallel.

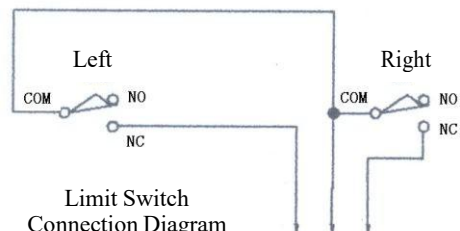

Limit Switch Connection Diagram

2.4 Connection of Encoder

Caution

- As the traction machine must be supplied with power by special inverter and adopt the closed loop control mode, a position feedback device (encoder) should be installed.



Caution

- The encoder shielded cable must be reliably grounded on single end.

- Considering the feedback signals of encoders may be different according to the control mode of inverter, the Company provides corresponding types of encoders for customers.

	Type	Pulse	Source
Standard	Sin/Cos	2048 P/R	5VDC
Optional	ABZ	8192 P/R	5VDC

- Detailed parameters and wiring definitions of encoder can be seen in the encoder instruction.
- The outgoing line at the end of encoder is connected to the outgoing line box, and the line outgoing method adopts aviation plug.
- The Company provides 7m encoder extended shielded cable so as to facilitate wiring by customers.
- The method of connecting the encoder extended line to the inverter side can be customized according to customer requirements.

2.5 Connection of Safety Switch

Caution

- According to the standard, the traction machine for machine room is furnished with one safety switch for barring device, and two normally open/normally closed contacts can be used by user in wiring.

2.6 Installation of Brake Releaser

Caution

- The mechanical brake releaser can only be used in case of failure to the elevator and the rescue in power failure.
- Please keep the brake releaser out of the reach of people, and forbid using it if not in an emergency.

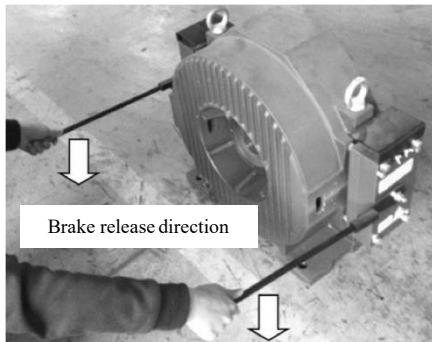

- The brake releaser can be used when there is machine room or not.
- The brake releaser with machine room will work after screwing in the brake handle releaser. (As shown in left figure)
- Please install and use the brake wire releaser with machine roomless according to the figure below. (As shown in the figure below)

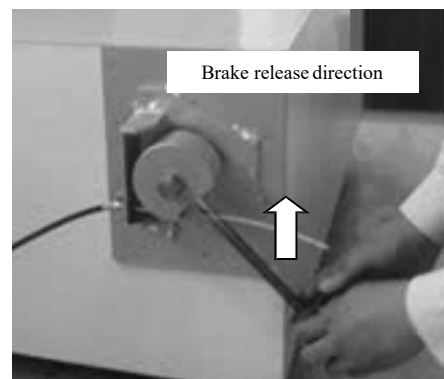
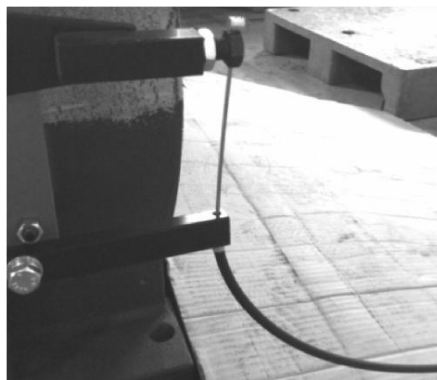

Brake Wire Releaser for Machine Roomless (see details in Appendix 7.2)

3. Debugging and Running

3.1 Debugging



Caution

- Debugging of traction machine must be conducted by professional technician who has been trained.
- As the traction machine might vibrate in debugging, please reliably fix the traction machine before debugging.
- For the purpose of stable running of traction machine, please set the inverter according to the date on nameplate and conduct self-learning.
- To use running self-learning function, be sure to release the steel wire rope, and energize the brake to work normally.
- Conduct self-learning on the origin of encoder at least three times and the self-learning angle deviation should be within 5°.

3.2 Running

- Run the machine at forward and reverse directions at low speed (inspection speed), and confirm whether the system can work normally.
- Run the machine at variable speed for certain time and at the same time, monitor whether the running current is within reasonable range.
- When the elevator is running at rated lift speed, the comfort adjustment of lift car can be set according to corresponding parameters of inverter.

4. Maintenance

4.1 Maintenance Checklist

Conduct regular inspection of maintenance according to the contents in the table below:

Inspection cycle	Inspection item	Criteria
Once a month	Vibration of traction machine body	No significant jitter
	Sound of traction machine body	No abnormal mechanical noise and accompanying mechanical vibration sound
	Odor of traction machine body	No abnormal odor
	Cleanness of traction machine surface	No foreign matter and dust attached
	Connection to mechanical equipment	No very big vibration or sound
	Brake wheel face	No foreign matter and greasy stain
Once every three months	Braking system	Reliable action and reliable braking
	Brake gap	No foreign matter, and reliable opening and closing. Gap is less than 0.1mm in picking up, and within 0.25~0.35mm in releasing.
	Brake shoe thickness	Wear extent of brake shoe < 2mm
	Sound of bearing	No discontinuous sound or abnormal sound
	Temperature of traction machine and brake	The temperature is not too high or is not largely different from the temperature of last time
	Running current value	Below the rated current indicated on nameplate
Once every six months	Traction sheave appearance	No looseness and damage
	Rope groove of traction sheave	No foreign matter, greasy stain and severe wear
	Anti-trip rope and protective cover	No looseness and displacement
	Screws in all positions of traction machine	No looseness
	Appearance of outgoing line	No damage and ageing
	Ground wire terminal	No looseness
Once a year	Insulation resistance of stator	More than 0.5MΩ

4.2 Supply of Lubricating Grease to Bearing

The life design for bearing meets the requirements of running for ten years, so it's not needed to fuel without special reasons.

When needing fueling, please inject Mobil grease XHP222 (NLGI Grade 2)



Caution

- In supplying the lubricating grease to bearing, please pay attention to rotating parts of motor and the elevator must be in stopped status.
- In supply, inject the lubricating grease of same brand and same specification, and if the different lubricating greases are mixed, the service life of lubricating grease will be shortened.
- If there is oil outlet seal cover in the supply, remove it when injecting oil, and after supply, restore it.
- In supply, slowly inject the lubricating grease with the special lubricating grease supply gun, and if it is too hasty, the lubricating grease will leak along the bearing surface.
- After supply, the bearing temperature might rise for a short time when the traction machine runs, and it will be reduced after certain time, so please don't worry about the rise of bearing temperature.

• Oil injection method for MCK100/MCK300

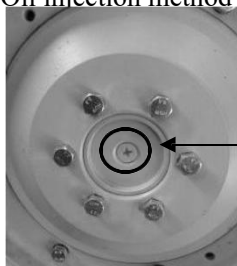

Oil filling port / discharge outlet

- The supply position is in the center of traction sheave.
- Before injecting oil, remove the sealing screw.
- Take out the residual oil at the oil filling port/discharge outlet.
- Slowly inject 10-20g lubricating grease.
- After injecting oil, restore the screw.

• Oil injection method for MCK200/MCK500

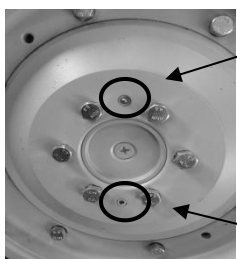

Oil filling port

discharge outlet

- The supply position is in the front of traction sheave.
 - Before injecting oil, remove the sealing screw.
- Wipe off the residual oil at the discharge outlet.
- Slowly inject 10-20g lubricating grease.
- After injecting oil, restore the screw.

5. Fault Diagnosis



Caution

- The traction machine fault diagnosis must be conducted by professional technician who has been trained.
- When the lift car is in hanging status, don't open both sides of the brake at the same time to prevent safety accidents.
- The adjustment of brake can be seen in Appendix 7.1, and in adjustment, be safe and guarantee enough braking force.
- The replacement of encoder can be seen in Appendix 7.3, and in replacement, power off the elevator, and after replacement, conduct self-learning.

Common faults and handling table:

No.	Fault	Inspection method	Countermeasures
1	The brake cannot be opened.		
1.1	Fail to energize or the voltage is incorrect	Check the brake wiring and its power supply voltage value.	Replace / adjust the control cabinet
1.2	Rectifier module is damaged	Check the rectifier module wiring and its output voltage value.	Replace the rectifier module
1.3	Brake coil is damaged or destroyed.	Check the brake coil resistance value.	Replace the brake
1.4	The brake gap is too big or there is foreign matter	Check the brake gap	See details in Appendix 7.1
2	The brake is not synchronous		
2.1	The stroke of brake arms of both sides is not appropriate	Check the brake gap	See details in Appendix 7.1
2.2	The brake on single side is in failure	The same as 1.3/1.4	<-
3	The brake sound is too big		
3.1	The brake gap is too big	Check the brake gap	See details in Appendix 7.1
3.2	The fit of brake shoe face is not normal	Check the brake gap	See details in Appendix 7.1
4	The band brake runs		
4.1	The brake gap is too small	Check the brake gap	See details in Appendix 7.1
4.2	The brake is in failure	The same as 1.1/1.2/1.3/1.4	<-
4.3	The fit of brake shoe is not normal	The same as 3.2	<-
5	The brake is overheated		
5.1	The brake coil is damaged	The same as 1.3	<-
5.2	The continuous operating ratio of brake is too big	Monitor the running condition of elevator	Replace the brake or machine with high load duration factor
6	The detection switch of brake is in failure		
6.1	Detection switch is damaged	Check the detection switch action state	Replace the detection switch and see details in Appendix 7.1
6.2	The detection switch stroke is not appropriate	Check the detection switch position and adjusting block stroke	Adjust the adjusting block and see details in Appendix 7.1
7	The traction machine is rolling		
7.1	The steel wire rope slips	Check whether there is oil and other foreign matters in traction sheave rope groove.	Remove the greasy stain and other foreign matters
7.2	There is oil and other foreign matter between brake wheel and brake shoe	Check the brake wheel and brake shoe face.	Remove the greasy stain and other foreign matters
7.3	The brake is in failure.	The same as 2.1/2.2	<-
7.4	The brake opening / closing is not appropriate	Check the set action time of inverter/brake control contactor	Adjust the brake opening / closing time
7.5	The inverter parameter setting is not appropriate	Check the inverter start / stop set parameters	Adjust the inverter start / stop set parameters
7.6	The elevator configuration / wrap angle / rope groove angle is not appropriate	Confirm the elevator balance coefficient and configuration, and recheck the traction force	Recheck whether the machine rolls when the load is balanced
8	The sound of steel wire rope is too loud		
8.1	The tension force of each steel wire rope is inconsistent	Compare the tension force of each steel wire rope	Adjust the steel wire rope
8.2	The tension force of steel wire rope is too tight / too loose.	Check the tension force of steel wire rope	Adjust the steel wire rope
8.3	The traction sheave rope groove is worn out	Check the traction sheave rope groove	Replace the traction sheave
8.4	There is foreign matter in traction sheave rope groove	Check whether there is foreign matter in traction sheave rope groove	Replace the traction sheave
8.5	The traction machine/guide wheel inclines	Check whether the traction machine installation position/whether the guide wheel inclines.	Adjust to correct position.

Operation Instruction for Permanent Magnet Synchronous Gearless Traction Machine

No.	Fault	Inspection method	Countermeasures
9	There is sound when the traction machine starts / stops (No sound during running)		
9.1	The brake sound is too big	The same as 3.1/3.2 if irrelevant to loading	<-
9.2	"Bang" second sound from traction machine when starting / stopping	If relevant to loading, the sound is the loudest in empty descending (full-load ascending), and is the lightest in half load/balanced load.	Adjust the parameter of inverter (modify the braking slope) or adjust the balance coefficient
9.3	There is "rattle" sound when the traction machine starts	Check the inverter starting set parameters	Adjust the inverter starting set parameters
9.4	There is "hum" sound when the traction machine brakes	Check the inverter braking set parameters Check whether the control cabinet release unit works reliably (it can be rechecked in car rolling method)	Adjust the inverter braking set parameters Adjust (replace) the release circuit
10	The traction machine has abnormal sound		
10.1	Electric sound ("sizzle / buzz" sound)	a. Check whether the grounding is reliable	Conduct reliable grounding
		b. Check whether the brake is opened reliably	The same as 4.1/4.2/4.3
		c. Check whether the traction machine is over the ground	Contact the Company
		d. Check the initial set parameters of inverter	Implement self-learning
		e. Check whether the empty descending (full-load ascending) current exceeds the rated value.	Confirm the traction machine type / contact the Company
		f. Check whether there is electric sound when the empty descending (full-load ascending) current doesn't exceed the rated value.	Adjust the inverter carrier wave / adjust the inverter running parameters Contact the Company
		g. Check whether there is electric sound when the empty ascending (full-load descending) current doesn't exceed the rated value.	The same as 8.4
		h. Check whether the three-phase current is stable	Re-measure the three-phase resistance, and if the amount of unbalance exceeds 5%, contact the Company, and if the resistance is balanced, replace the inverter.
10.2	Mechanical sound ("rustle / click" sound)	a. The same as 10.1.b	<-
		b. Check whether there is mechanical sound in certain layer in empty descending (full-load ascending)	Adjust the elevator installation
		c. Check whether there is sound in half load (balanced load)	The same as 10.1.f
		d. Check whether the sound is bearing sound (it is relevant to speed and is regular)	Contact the Company
		e. Check whether the sound is friction / impact sound from the box	Contact the Company
10.3	Mixed sound (noise)	a. The same as 10.1.b	<-
		b. Compare the empty ascending / descending (full-load descending / ascending) sound, and check whether they are obviously inconsistent.	The same as 10.1.c/10.1.d/10.1.e/10.1.f/10.1.g/10.1.h
		c. Compare the empty descending (full-load ascending) / half-load (balanced load) sound, and check whether they are obviously inconsistent.	The same as 10.2.c
		d. Compare whether the sound at different speeds is obviously inconsistent.	The same as 10.2.d
11	The lift car vibrates		
11.1	The steel wire rope trembles	a. The same as 10.1.b	<-
		b. The same as 8.1/8.2/8.3/8.4/8.5	<-
		c. Check whether the safety tongs/guide shoe is too tight.	Adjust the elevator installation
		d. Check whether the guide rail is obviously deformed.	Adjust the elevator installation
11.2	It is not comfortable in some section	The same as 10.1.d	<-
11.3	It is not comfortable when starting / stopping	The same as 9.2.b	<-
11.4	It is not comfortable during running	The same as 4.1/4.2/4.3/8.3/8.4	<-
12	The encoder is in failure	The same as 9.1.c/9.1.d/9.1.e/9.1.f/9.1.g/9.1.h/9.2.c/9.2.d	<-
12.1	The traction machine is not well grounded	The same as 10.1.a	<-
12.2	The encoder signal line is interfered	Check whether there is active force line or other interference source beside the encoder line	Separate the encoder line from interference source
12.3	The encoder is not well grounded	Check whether only one end of encoder shielded line is grounded and reliably grounded.	Keep certain distance between interference source and encoder line as much as possible
12.4	The encoder origin angle is inaccurate /lost	Check the origin value of inverter encoder	Implement self-learning of inverter for three times. The encoder origin angle deviation should be within 5°
12.5	The encoder jitter is big	Check whether the encoder has obvious twist in running.	Adjust the encoder bracket or mounting shaft / replace the encoder
12.6	The encoder signal line is in failure	Check whether the encoder signal line has indentation and other obvious damage.	Replace the encoder signal line
12.7	The encoder wiring is wrong	Check whether the encoder wiring corresponds to the terminal of inverter PG card.	Conduct wiring according to correct requirements
12.8	The encoder and PG card don't match	Check the type of supporting encoder of inverter PG card	Replace PG card or encoder
12.9	The encoder body is in failure	Check whether the encoder has impact and other obvious damage The encoder loses or doesn't have signal output	Replace the encoder

6. Emergency Rescue



Caution

- Emergency rescue is implemented when the elevator is in failure or people are trapped due to power failure, and it must be implemented by people who have received special training and possessed the elevator repair certificate.
- For the facilities with machine room, use the brake handle releaser and barring device provided by the Company; and for the facilities machine roomless, please use the brake wire releaser.
- Before emergency rescue, please cut off the main power supply of elevator, to prevent accidental starting of elevator, but it's required to keep the lighting of lift car and stabilize the trapped people's mood.
- Confirm the position of lift car, and when the elevator stops on certain floor and there is a rescue space more than 0.5m, directly open the lift car door to implement rescue.
- If the lift car is not in the above position, move the lift car in mechanical method, and when the rescue space more than 0.5m is available, implement rescue.
- Before manual barring, two persons hold the barring hand wheel, and another manually operates the brake releaser tightly and loosely alternately. The brake releaser can disable the brake only when the lift car moves; otherwise, immediately cancel such action. When the lift car doesn't exceed the top layer or bottom layer, move the lift car toward the labor-saving direction, and when the lift car exceeds the top layer or bottom layer, move the lift car in opposite direction, and when necessary, move it through barring hand wheel.

7. Appendix

7.1 Adjustment of Brake

Brake Structure Diagram

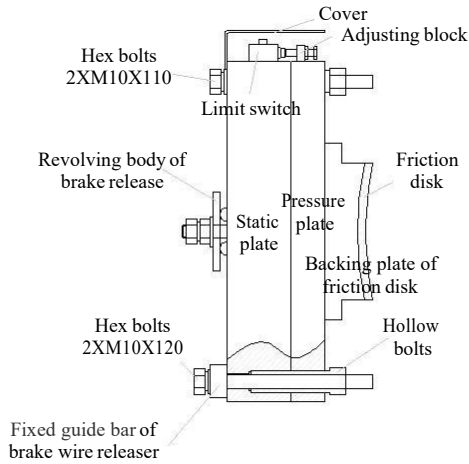

Caution

- The braking system has been pre-adjusted before leaving the factory, so please don't adjust it when unnecessary.
- The brake must be adjusted by professionals who have been trained.
- When the lift car is in hanging status, don't open both sides of the brake at the same time.
- When adjusting the brake, be safe and guarantee enough braking force.
- This chapter introduces the adjusting method, and for the parts not described, forbid adjusting them.

7.1.1 Adjustment of brake gap

- Adjust the brake gap (the distance between static plate and pressure plate), and when picking up, the brake gap should be less than 0.1mm, and when releasing, it should be within 0.25~0.4mm.
- Check the air gap in one corner of brake with 0.3 thickness gauge. When the air gap is less than 0.3mm, loose the mounting bolt of such corner counterclockwise, rotate the hollow bolt clockwise at a small angle, and then lock the mounting bolt.

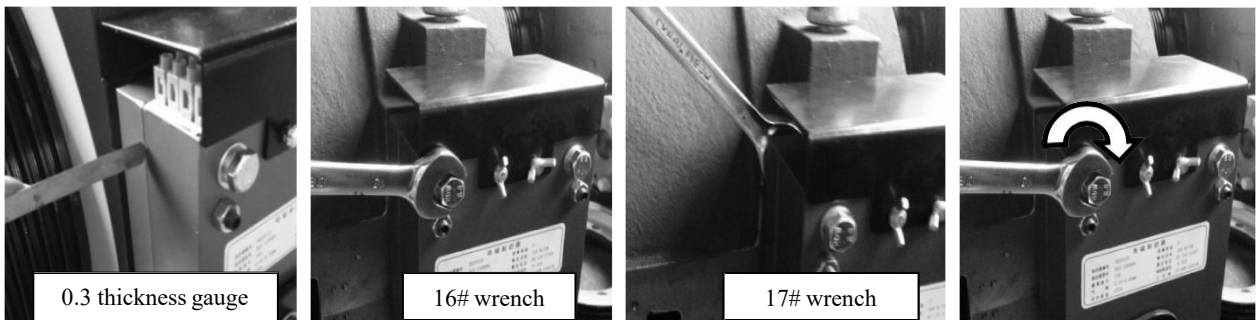

- Check the air gap of such corner with 0.35mm thickness gauge. When the air gap is more than 0.35mm, loose the mounting bolt of such corner counterclockwise, rotate the hollow bolt counterclockwise at a small angle, and then lock the mounting bolt.



- Adjust the gap of all corners of brake, and ensure that 0.3mm thickness gauge can pass but 0.35mm thickness gauge cannot pass.

7.1.2 Adjustment of brake stroke

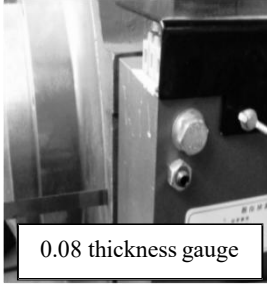

- When the brake is in picked-up state (power on), check the gap between brake wheel face and brake friction disk face with 0.08mm thickness gauge, and if the gap is less than 0.08mm, repeat 7.1.1 adjustment of brake gap, and finely adjust the gap of wheel face to be not less than 0.08mm.

7.1.3 Adjustment of limit switch

- Remove the cover on the top of brake, and adjust the adjusting block of limit switch to realize that the limit switch can be reliably opened / closed accordingly when the brake is opened / closed, and after adjusting, restore the cover.

7.2 Brake Wire Releaser for Machine Roomless



Caution

- Before operation, confirm that the main power supply is turned off.
- Forbid any adjustment to the brake.
- Don't adjust the fixed brake release parts.



Caution

- Both ports of wire cable and protective cover must be parallel and can slide freely, to prevent friction and damage of wire cable due to too big bend angle.
- When arranging the brake wire, the wiring radius should be more than 0.5m, and the reserved wire can be appropriately adjusted according to practical situation.
- When arranging the brake wire and using such device, forbid damaging the protective cover of brake wire, and if it is damaged, the brake wire releaser may fail.
- When arranging the brake wire, it should be fixed with the special cable presser and not be too tight; otherwise, the brake wire releaser may fail.
- After finishing assembling the brake wire releaser, try to pull it for several times and ensure that it operates flexibly and can be automatically restored, and in case of any problem, readjust it; otherwise, forbid using it.

Structure diagram of Brake Wire Releaser for Machine Roomless

- 1 - Handle
- 2 - Compression bolt, washer
- 3 - Rotary table
- 4 - Brake wire cable
- 5 - Base
- 6 - Threading screw
- 7 - Nut
- 8 - Hex bolt
- 9 - Fixed screw
- 10 - Fixed link

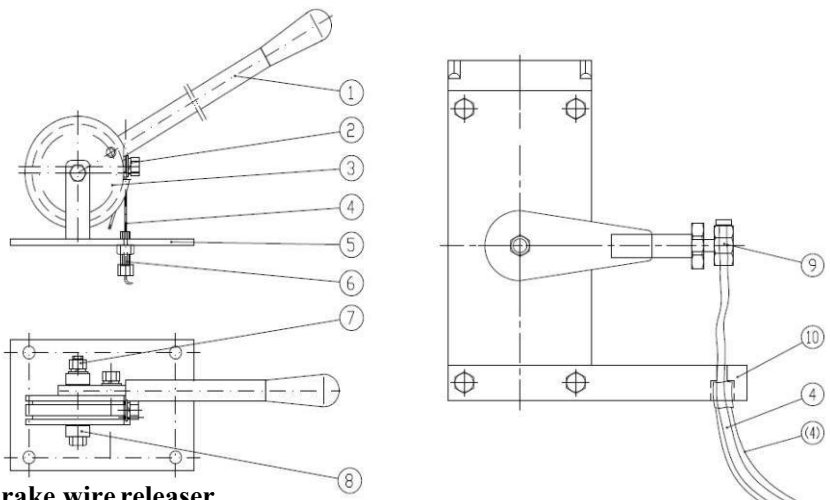

7.2.1 Assembling step one of brake wire releaser

- Pull out the wire of brake cable from the protective cover, get the wire through the small holes of fixed screw (9) and fixed link (10) vertically in sequence, and then tighten the brake release cable. Get the brake cable through the cover again, and push one end of cover into the counter bore of fixed link (10).

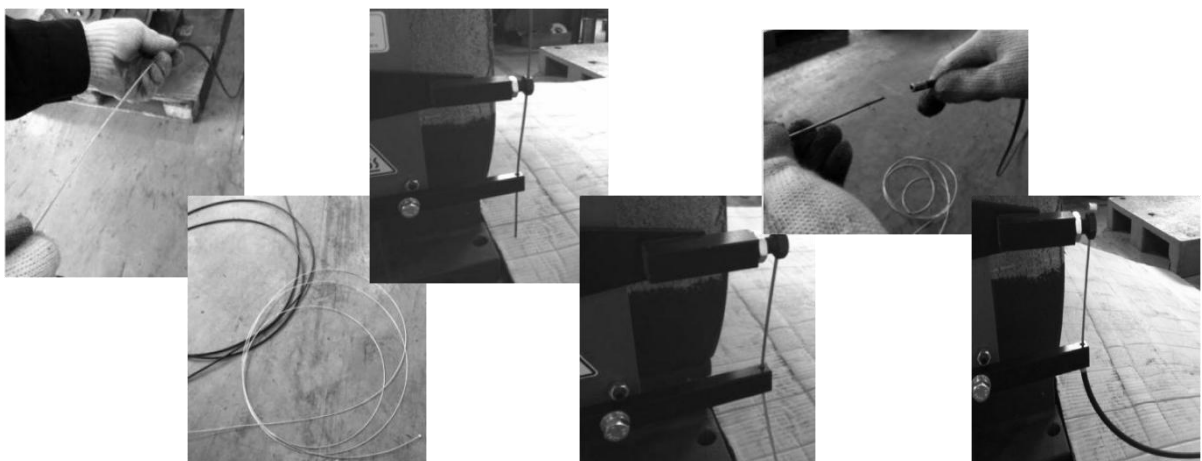

7.2.2 Assembling step two of brake wire releaser

- Get the end of brake cable through threading nut (6), and bend the head of steel wire rope for 20-30mm at 180° with a flat tongs. Lock the elbows with compression screw and washer (2) with 13# open-end wrench.

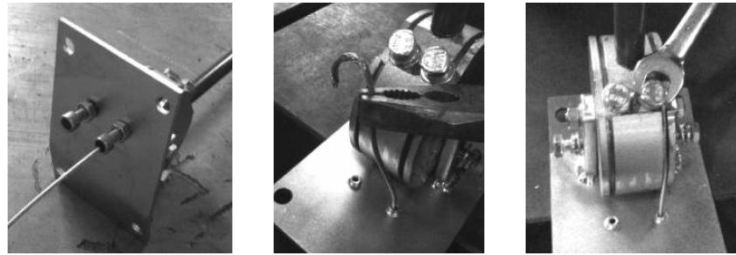

7.2.3 Install the brake wire releaser cable of brake on the other side in the same way. Finally install the base in the appropriate force bearing point.

7.2.4 Use method

- Rotate around the supporting point (hex bolt) with the handle of brake releaser, as shown in the figure below, and the brake is opened; then finish the brake releasing action. When releasing the brake, pay attention to rolling speed and car cabin leveling, and after finishing leveling, immediately loosen the handle and stop releasing the brake. After finishing releasing the brake, the handle and brake release cable must be restored.

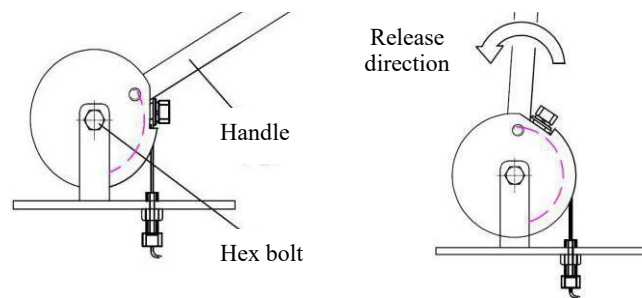

7.3 Replacement of Encoder

⚠ Caution

- Don't touch bare terminals of encoder with bare hand.
- Don't knock, hammer and impact the encoder body.
- Don't coat thread locking adhesive onto the mounting screw of encoder.
- After replacement of encoder, conduct self-learning again.

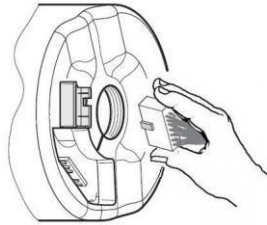
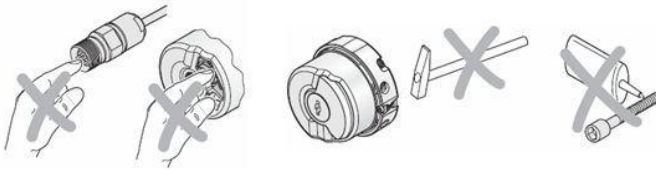

⚠ Caution

- Plug and unplug the wiring terminal of encoder in the method as shown in the left figure.
- Please press the copper hoop on encoder wire into the card slot as shown in the right figure.

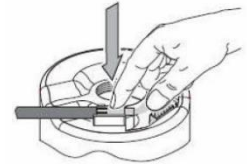

- The standard encoder adopts the cone axis hole connection and outer ring expansion structure.
- Please dismantle the encoder in the method and sequence as shown in the figure below.

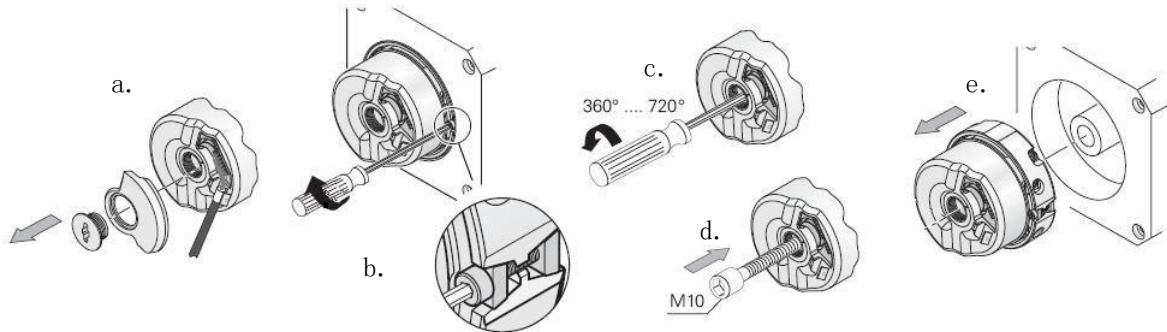

- Remove the rear dust cover of encoder with 3mm hexagon wench.
- Loosen the outer ring expansion screw of encoder with 2mm hexagon wench.
- Loosen M5 mounting screw of encoder with 4mm hexagon wench (2~4 circles).
- Screw in M10 screw with 8mm hexagon wench to push out the encoder.
- Hold the encoder with hand, gently remove it and put it in a safe position.

- Please install the encoder in the method and sequence as shown in the figure below.

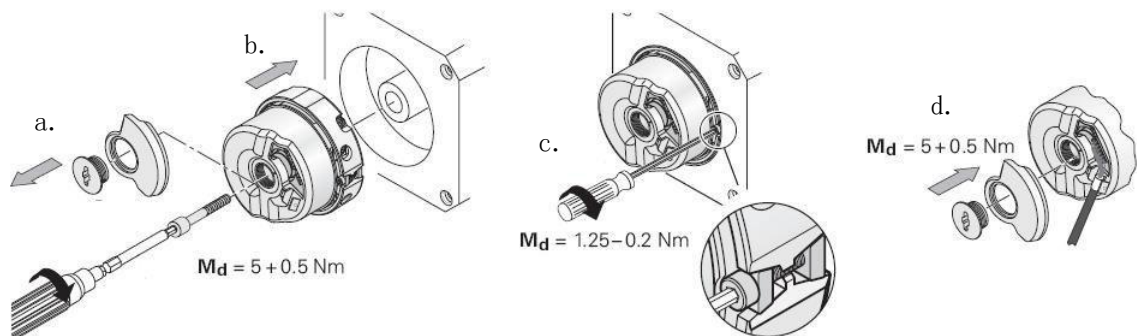

- Remove the rear dust cover of encoder with 3mm hexagon wench.
- Fasten M5 mounting screw of encoder with 4mm hexagon wench (locking force is $5+0.5N.m$).
- Fasten the outer ring expansion screw of encoder with 2mm hexagon wench (locking force is $1.25-0.2N.m$).
- Fasten the rear dust cover of encoder with 3mm hexagon wench (locking force is $5+0.5N.m$).